

GPS 17/17N

GPS receiver/antenna

quick
start
guide



© 2001 GARMIN Corporation

GARMIN International, Inc.
1200 East 151st Street, Olathe, Kansas 66062, U.S.A.
Tel. 913/397.8200 or 800/800.1020
Fax 913/397.8282

GARMIN (Europe) Ltd.
Unit 5, The Quadrangle, Abbey Park Industrial Estate, Romsey, SO51 9AQ, U.K.
Tel. 44/1794.519944
Fax 44/1794.519222

GARMIN Corporation
No. 68, Jangshu 2nd Rd., Shijr, Taipei County, Taiwan
Tel. 886/02.2642.9199
Fax 886/02.2642.9099

All rights reserved. Except as expressly provided herein, no part of this manual may be reproduced, copied, transmitted, disseminated, downloaded or stored in any storage medium, for any purpose without prior written consent of GARMIN Corporation. GARMIN Corporation hereby grants permission to download a single copy of this manual onto a hard drive or other electronic storage medium to be viewed for personal use, provided that such electronic or printed copy of this manual contains the complete text of this copyright notice and provided further that any unauthorized commercial distribution of this manual is strictly prohibited.

Information in this manual is subject to change without notice. GARMIN Corporation reserves the right to change or improve its products and to make changes in the content without obligation to notify any person or organization of such changes. Visit the GARMIN web site (www.garmin.com) for current updates and supplemental information concerning the use and operation of this and other GARMIN products.

GARMIN® and AutoLocate® are registered trademarks of GARMIN Corporation and may not be used without the express permission of GARMIN Corporation.

GARMIN Corporation warrants this product to be free from defects in materials and workmanship for one year from the date of purchase. GARMIN will, at its sole option, repair or replace any components that fail in normal use. Such repairs or replacement will be made at no charge to the customer for parts or labor. The customer is, however, responsible for any transportation costs. This warranty does not cover failures due to abuse, misuse, accident or unauthorized alteration or repairs.

THE WARRANTIES AND REMEDIES CONTAINED HEREIN ARE EXCLUSIVE AND IN LIEU OF ALL OTHER WARRANTIES EXPRESS OR IMPLIED OR STATUTORY, INCLUDING ANY LIABILITY ARISING UNDER ANY WARRANTY OF MERCHANTABILITY OR FITNESS FOR A PARTICULAR PURPOSE, STATUTORY OR OTHERWISE. THIS WARRANTY GIVES YOU SPECIFIC LEGAL RIGHTS, WHICH MAY VARY FROM STATE TO STATE.

IN NO EVENT SHALL GARMIN BE LIABLE FOR ANY INCIDENTAL, SPECIAL, INDIRECT OR CONSEQUENTIAL DAMAGES, WHETHER RESULTING FROM THE USE, MISUSE, OR INABILITY TO USE THIS PRODUCT OR FROM DEFECTS IN THE PRODUCT. SOME STATES DO NOT ALLOW THE EXCLUSION OF INCIDENTAL OR CONSEQUENTIAL DAMAGES, SO THE ABOVE LIMITATIONS MAY NOT APPLY TO YOU.

To obtain warranty service, contact your GARMIN dealer or call the GARMIN Customer Service department (913-397-8200) for a returned merchandise tracking number. The unit should be securely packaged with the tracking number clearly marked on the outside of the package and sent freight prepaid and insured to a GARMIN warranty service station. A copy of the original sales receipt is required as the proof of purchase for warranty repairs. GARMIN retains the exclusive right to repair or replace the unit or software or offer a full refund of the purchase price at its sole discretion. SUCH REMEDY SHALL BE YOUR SOLE AND EXCLUSIVE REMEDY FOR ANY BREACH OF WARRANTY.

Limited Warranty



The GARMIN GPS 17/17N has no user-serviceable parts. Should you ever encounter a problem with your receiver, please contact your GARMIN dealer or the GARMIN Customer Service department (913-397-8200 or 800-800-1020) for repairs. Any attempt to open the case to change or modify the unit in any way will void your warranty and may result in permanent damage to the equipment.

Serial Number

Use this area to record the serial number (8-digit number located on the bottom of the antenna) in case it is lost, stolen, or needs service. Be sure to keep your original sales receipt in a safe place or attach a photocopy inside the manual.

Serial Number:

--	--	--	--	--	--	--	--

Cautions

The GPS system is operated by the government of the United States which is solely responsible for their accuracy and maintenance. The Global Positioning System and the Differential Global Positioning System are under development and are subject to changes which could affect accuracy and performance of all GPS equipment. Although a GPS system is a precision electronic NAVigation AID (NAVAID), any NAVAID can be misused or misinterpreted, and therefore become unsafe. Use the GPS system at your own risk. To reduce this risk, carefully review and understand all aspects of this Quick Start Guide and carefully compare indications from your display to all available navigation sources including the information from other NAVAIDs, visual sightings, charts, etc. For safety, always resolve any discrepancies before continuing navigation.

NOTE: This device complies with Part 15 of the FCC rules. Operation of this device is subject to the following conditions: (1) This device may not cause harmful interference, and (2) this device must accept any interference received, including interference that may cause undesired operation.

Table of Contents

Introduction

Limited Warranty.....	1
Cautions	2
Table of Contents	3

Overview

Capabilities & Package Contents.....	4
Specifications.....	5

Installation

Mounting the GPS 17/17N.....	6-8
Wiring the GPS 17N.....	9-10

Operation

Using the GPS 17/17N	11-12
----------------------------	-------

Capabilities & Package Contents

Capabilities

The GPS 17/17N offers a host of powerful capabilities for enhanced performance and accuracy:

- **Performance**— WAAS enabled, 12-channel GPS receiver tracks and uses up to 12 satellites for fast, accurate positioning.
- **Ease of Use**— Once installed, unit will automatically transmit navigation data.
- **Convenience**— May be remotely mounted in an out-of-the-way location. Receiver status information is displayed directly on the chartplotter or PC.
- **Low Power Consumption**— Draws approximately 65 milliamps during normal operation.
- **GPS Accuracy**
 - Position: < 15 meters, 95% (typical)*
 - Velocity: .1 knot RMS steady state
- **DGPS (USCG) Accuracy**
 - Position: 3-5 meters, 95% (typical)
 - Velocity: .1 knot RMS steady state
- **DGPS (WAAS) Accuracy**
 - Position: < 3 meters, 95% (typical)
 - Velocity: .1 knot RMS steady state

Package Contents

Your GARMIN GPS 17/17N package includes:

- GPS 17/17N unit
- 30' Power/Data Cable
- Quick Start Guide

If any parts are missing or damaged, please contact your GARMIN dealer immediately.

* Subject to accuracy degradation to 100m 2DRMS under the U.S. Department of Defense imposed Selective Availability Program.

Physical

Size:	3.58" D x 4.25" H (91mm x 108mm)
Weight:	1.0 pound (0.373 kg)
Operating Range:	-40°F to +176°F (-40°C to +80°C)
Waterproof:	-1 meter submersion for 30 minutes IPX7 rating for IEC529
Mount Thread Size:	1" diameter at 14 threads/inch
Cable:	Foil-shielded 8 conductor 28 AWG GPS 17- RJ-45 Connector GPS 17N- Bare wire leads
Dynamics:	999 knots, 6g's

Power

Voltage:	6 - 40 Vdc unregulated
Current Drain:	65 mA @ 12 Vdc 28 mA @ 40 Vdc
Sensitivity:	-165 dBW minimum

Interfaces

Serial Port 1:	Selectable between NMEA and GARMIN. NMEA 0183 v2.0 (ASCII), GPALM, GPGGA, GPGLL, GPGSA, GPGSV, GPRMC, GPVTG, PGRME, PGRMF, PGRMT and PGRMV output.
Serial Port 2:	RTCM Input Only. RTCM SC-104 differential input message types 1, 2, 3, 7 and 9
Baud Rates:	300 -19200

GPS 17/17N Specifications



Complete information concerning NMEA & RTCM formats and sentences is available for purchase at:

National Marine Electronics Association (NMEA)
PO Box 3435
New Bern, NC 28564-3435
USA
252-638-2626
252-638-4885 FAX.
www.nmea.org

Radio Technical Commission For Maritime Services (RTCM)
1800 Diagonal Road, Suite 600
Alexandria, VA 22314-2480,
USA
703-684-4481 (Info Only)
703-836-4229 FAX
www.rtcn.org

Mounting the GPS 17/17N

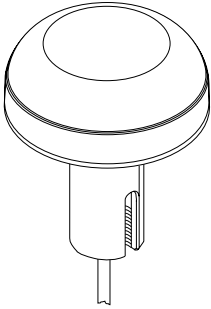

Note: As a general rule, mount the receiver at least three feet from all other antennas and the vessel's electrical system components (alternator/ignition system).

Mounting the Receiver

Please read through these instructions thoroughly before attempting installation. Make sure you completely understand these instructions before you begin. When in doubt, seek professional assistance.

The following additional items are needed or optional to complete the installation of your GPS 17/17N:

- **Antenna mount**— Since antenna mounting locations and methods vary, you will need to obtain an antenna mount to install the GPS 17/17N. The receiver base fits a standard 1-inch, 14 threads-per-inch marine mount. Check with your GARMIN dealer or a marine supply retailer for this item.
- **On/Off switch (optional)**— Power to the receiver may be controlled by an on/off switch, such as an accessory switch on the control console. Check with your GARMIN dealer or a marine/electric supply retailer for this item.

It is recommended that the system be temporarily hooked up with the wiring and the unit placed at the desired installation location. Then, check operation with potential interfering equipment turned on and off. (For example, other electronic equipment, fan motors, engine ignition, alternators, generators, radars and VHF radio transmissions can be sources of interference.)

Position the receiver so that the clearest possible view of the sky and horizon in all directions is obtained. Avoid mounting the antenna next to large areas of conductive material (metal, aluminum, etc.) as this may cause poor signal reception. It is not recommended that the GPS 17/17N be mounted high on a mast, as the top of the mast travels more than the boat. The unit will provide more stable readings if it is located nearer to the water level. The GPS 17/17N is supplied with a 30 feet power/data cable. When routing the wiring to the GPS 17/17N, avoid routing the cable near the vessel's alternator or ignition system components or parallel to other power lines.

Three common sources of interference for GPS units are:

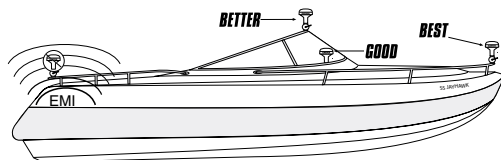
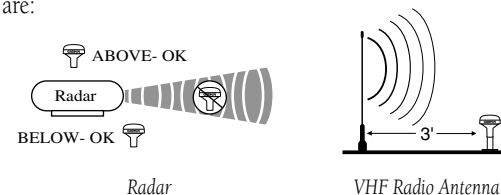

EMI (Electromagnetic Interference) from engine components

If a problem is found, try altering the location of the unit or wiring. Often moving the antenna a few feet away from the source of interference will solve the problem. When a suitable configuration is found, a permanent installation should be made. Select the mounting location according to your preferences. Keep in mind that from this mounting location cables will be routed to the NMEA listening device.

Mounting the GPS 17/17N with cable outside mount:

1. Place the cable in the vertical slot along the side of the base of the unit.
2. Screw the GPS 17/17N onto the mount. Make sure that you do not overtighten the head. It is possible to tighten the unit to the point that the cable may be cut in two.
3. With the GPS 17/17N and mount installed, fill the remaining gap in the cable exit on the with a marine sealant.
4. Route the power/data cable from the GPS 17/17N to the desired device. Excess cable may be shortened or coiled together and secured in an inconspicuous location.

Mounting the GPS 17/17N



When routing the power/data cable, try to avoid:

- Sharp edges which may cut the cable.
- Routing the cable parallel to other power lines.
- Excessively twisting, straining or bending the cable.

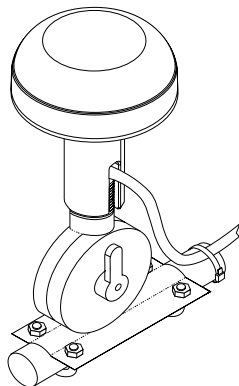

Installation

Mounting the GPS 17/17N

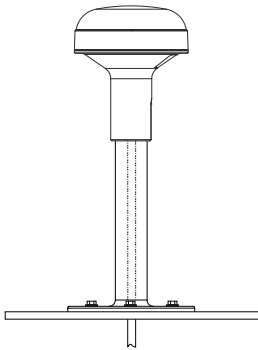
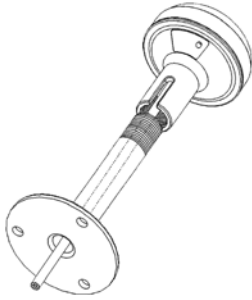

Mounting the GPS 17/17N with cable through mount:

1. Position the mount in the desired location and mark the approximate center of the mount
2. Drill a hole large enough for the cable (or RJ-45 connector) to pass through at the marked location.
3. Slide the cable through the mount and screw the GPS 17/17N onto the mount.
4. Fasten the mount to the boat
5. When running the cable, attempt to keep the cable away from sources of electronic interference.

Wiring the GPS 17/17N

The final step in installing the GPS 17/17N is to connect the receiver's Port 1 DATA IN, DATA OUT, REMOTE ON/OFF and GROUND (Return) lines to your NMEA device or PC. Port 2 is used for RTCM input only. The GPS 17 may be plugged directly into a RJ-45 receptacle, which accepts NMEA data. It is recommended that a 1A fuse be installed on the power (+) line of the receiving RJ-45 receptacle or equivalent device. Color coding of the wires is the same on both the GPS 17 and GPS 17N (see wiring diagrams on following pages). If necessary, the wire coloring on the GPS 17 may be seen through the clear RJ-45 connector.

For reliable communication, it is essential that the GPS 17/17N and the receiving device share the same ground. This ground connection acts as the (signal) Return line. It is recommended to wire the unit to its own circuit to avoid interference from other electronics.

Wire Coloring:

RED- Power (+) 6-40 Vdc

BLACK- Ground (Power (-) and Data Signal Return)

YELLOW- Remote power On/Off

BLUE- Port 1 NMEA Data Input

WHITE- Port 1 NMEA Data Output

GREEN- Port 2 RTCM Data Input

VIOLET- Port 2 RTCM Data Output (Reserved for Future Use)

GRAY- Pulse Per Second Output (See Technical Specifications)

Basic Wiring for the GPS 17N to a NMEA Device or PC Connector:

1. You may reference the following diagrams for the wiring: Connect the WHITE (Port 1 Data Out) wire from the GPS 17N's power/data cable to the DATA INPUT line of the NMEA device or to pin 2 on a DB9 (pin 3 on DB25). You may output data to no more than three NMEA devices.
2. Connect the BLUE (Port 1 Data In) wire to the DATA OUTPUT line of the NMEA device or pin 3 on the DB9 (pin 2 on DB25).
3. Connect the BLACK (-) wire to the GROUND wire of the NMEA device or pin 5 on the DB9 (pin 7 on DB25). If connecting to a PC, you must also run a separate BLACK (-) wire to a power ground. If the BLACK wire is connected to the same ground terminal as the NMEA device, no additional connection is required, unless a separate data return line is required by the the NMEA device).
4. Connect the RED (+) wire from the power/data cable to a 6-40 Vdc power source.
5. If a remote power switch is being installed, reference the following page for wiring a switch. This will allow the GPS 17/17N to remain connected to a power source, but manually powered on (pull down to less than 0.5 volts) and off (open). Otherwise, if the receiver is being wired to a circuit which is already switched, (with the NMEA device for example) connect the YELLOW wire to the same place as the BLACK wire. When the BLACK and YELLOW wires are combined, the GPS 17N will turn on/off when power is applied/removed to the RED (+) and BLACK (-) wires.

Wiring the GPS 17N



If the GPS 17/17N is being connected to a PC, a DB9 or DB25 serial connector (normally female) will be needed. Check with a PC or electronics supplier for this item.

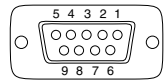

DB9 Female Serial Connector

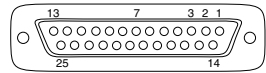

DB25 Female Serial Connector



Some non-GARMIN devices may have a separate data line labeled "RETURN", "DATA GROUND" or "DATA -". If one of these lines exist, connect the BLACK wire from the power/data cable to it.

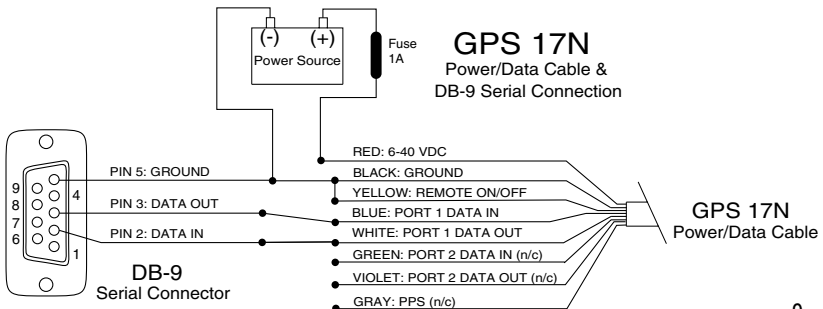

Installation

Wiring the GPS 17N

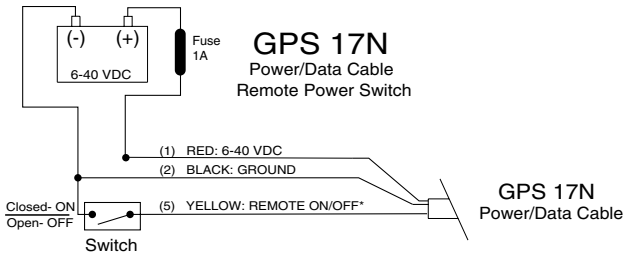
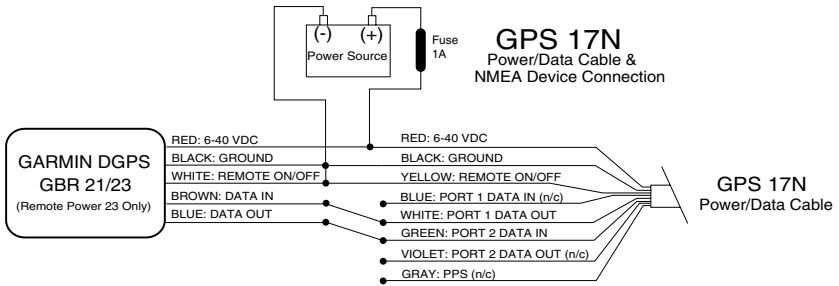
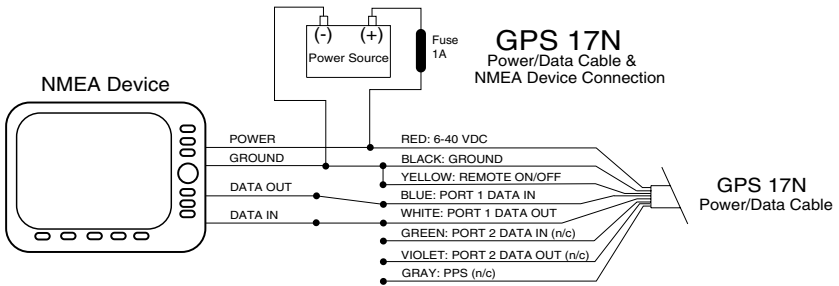

First Time Fix

The first time you power up your new GPS 17/17N, the receiver must be given an opportunity to collect satellite data and establish its present position. To ensure proper initialization, the GPS 17/17N is shipped from the factory in AutoLocate mode, which will allow the receiver to “find itself” anywhere in the world.

Once the GPS17/17N is installed and powered on, it will begin to search for satellites. The GPS 17/17N will output navigation data once it has calculated an initial position fix. By default, the following data will be output in NMEA 0183, Version 2.0 format:

- Latitude/Longitude/Altitude (GPGGA, GPRMC)
- Velocity (GPRMC)
- Date/Time (GPRMC)
- Error Estimates (PGRME)
- Satellite and Receiver Status (GPGSA, GPGSV, PGRMB, PGRMT)

WAAS Capability

The GPS 17/17N is capable of receiving WAAS (Wide Area Augmentation System) satellite signals. WAAS is an FAA (Federal Aviation Administration) funded project to improve the overall accuracy and integrity of the GPS signal for aviation use, but land/sea based users may also benefit from this system. At this time, the system is still in the development stage and is not fully operational. There are currently two WAAS satellites that can be received in the U.S.A., one over the Atlantic Ocean and one over the Pacific Ocean, in a geo-stationary orbit over the equator. Effective use of the WAAS satellite signal may be limited by your geographic location in relation to those satellites, now in developmental service. WAAS satellite signal reception requires an absolute clear view of the sky and works best when there are no nearby obstructions such as buildings, mountains, etc. WAAS satellites will be numbered 33 or higher when viewing the sky view on your NMEA device. Initial reception of the WAAS signal may take up to 15-20 minutes, then 1-2 minutes afterwards.

Using the GPS 17/17N



The following NMEA transmitted sentences are enabled at the factory: GPGGA, GPGSA, GPGSV, GPRMC, PGRMB, PGRME, PGRMT and PSLIB

When WAAS differential correction has been received for GPS satellites (numbers 32 or below), a 'D' will appear in the signal bar of the sky view and '2D or 3D Differential' will appear in the receiver status. To learn more about the WAAS system, its satellite positions and current state of development, visit the FAA web site (<http://gps.faa.gov>).

Interfaces

The GPS 17/17N serial Port 1 interface protocol design is based on the National Marine Electronics Association's (NMEA) 0183 ASCII interface specification, which is fully defined in "NMEA 0183, Version 2.0" and the Radio Technical Commission for Maritime Services "RTCM Recommended Standards For Differential Navstar GPS Service, Version 2.1, RTCM Special Committee No. 104". Contact information to obtain copies of the NMEA and RTCM specifications may be found on page 5.

Port 2 is designated for RTCM data input only. Output on Port 2 is reserved for future use.

The GPS 17/17N interface protocol also transmits additional information using the convention of GARMIN proprietary sentences (\$PGxxx). Complete information on GPS 17/17N capabilities, data transfer, NMEA sentence formats and descriptions can be found in the "GPS 17/17N Technical Specifications" (190-00228-20). You may order a copy of these specifications from GARMIN or your GARMIN dealer, or you may also download a copy from the manuals section of the GARMIN web site at www.garmin.com/support/userManual.html.

The GPS 17/17N Port 1 is capable of transmitting the following NMEA data sentences:

GPALM, GPGGA, GPGSA, GPGSV, GPRMC, GPVTG, GPGLL, PGRME, PGRMF, PGRMT, PGRMV and PGRMB

The GPS 17/17N Port 1 is capable of receiving the following NMEA data sentences:

GPALM, PGRMI, PGRMC, PGRMC1, PGRMO and PSLIB.



© 2001 GARMIN Corporation

GARMIN International, Inc.
1200 East 151st Street, Olathe, Kansas 66062, U.S.A.

GARMIN (Europe) Ltd.
Unit 5, The Quadrangle, Abbey Park Industrial Estate, Romsey, SO51 9AQ, U.K.

GARMIN Corporation
No. 68, Jangshu 2nd Rd., Shijr, Taipei County, Taiwan

www.garmin.com

Part Number 190-00228-10 Rev. A